

4611180000124

(带霍尔传感器)
(With hall sensors)

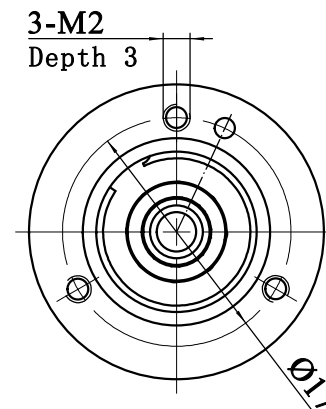
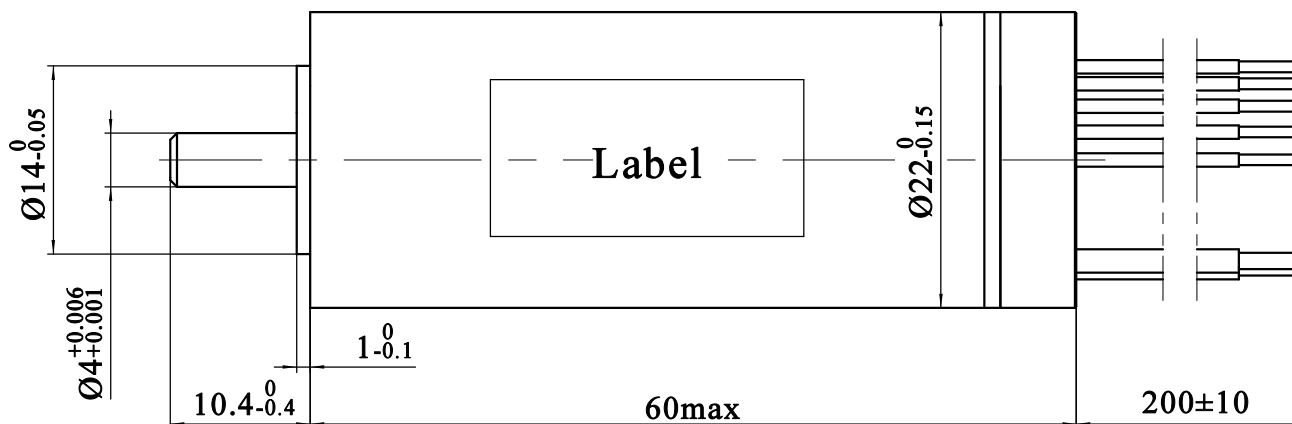
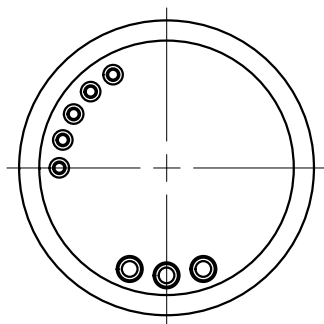

规格/Specifications	Values	Tolerance	Unit
额定电压/Nominal voltage	24	Typical	V
空载转速/No load speed	37000	±10%	RPM
空载电流/No load current	650	±50%	mA
名义转速/Nominal speed	36855	Typical	rpm
最大连续转矩/Max. continuous torque	29.76	Typical	mNm
最大连续电流/Max. continuous current	6.20	Typical	A
额定转速/Rated speed	27520	±10%	RPM
额定转矩/Rated torque	26.0	Typical	mNm
额定电流/Rated current	3.84	±10%	A
堵转转矩/Stall torque	795.37	Typical	mNm
堵转电流/Stall current	128.34	Typical	A
最大效率/Maximun efficiency	90	Typical	%
电机极数/Number of poles	2		
相数/ Number of phases	3		
相间电阻/Terminal resistance phase to phase	0.187	±8%	Ω
相间电感/Terminal inductance phase to phase	23.6	Typical	μH
转矩常数/Torque constant	6.20	Typical	mNm/A
转速常数/Speed constant	1541.67	±10%	RPM/V
机械时间常数/Mechanical time constant	1.57	Typical	ms
转子惯量/Rotor inertia	3.23	Typical	gcm ²
机壳热阻/Thermal resistance housing-ambient	12.7	Typical	K/W
电机质量/Weight of motor	135	±5%	g
使用温度范围/Ambient Temperature	-40~+100		℃

Connection (Cable AWG 18/26)

Cable No.	信号/Signal	颜色/Color
1	电机绕组1/Motor winding 1	红/red
2	电机绕组2/Motor winding 2	黑/black
3	电机绕组3/Motor winding 3	白/white
4	V _{Hall} 3...32VDC	橙/orange
5	GND	蓝/blue
6	霍尔传感器1/Hall IC 1	黄/yellow
7	霍尔传感器2/Hall IC 2	棕/brown
8	霍尔传感器3/Hall IC 3	灰/grey

铭牌/Label Detail

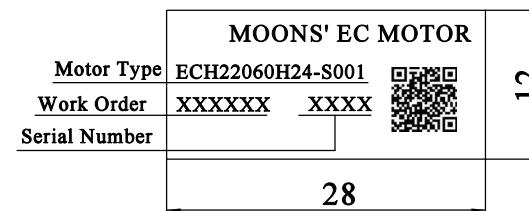

备注:

- 1、二维码内包括电机型号、加工单号和系列号。
- 2、铭牌位置纵向贴在电机中间。

G		
F		
E		
D		
C		
B		
A	原始版本 Original revision	2019.09.09
REV.	版本记录 REVISION RECORD	DATE

Unit: mm 第一角画法 FIRST ANGLE METHOD 未注线性与角度尺寸公差 Tolerances for linear and angular dimensions without individual tolerance indications GB/T 1804-m eqv ISO 2768-1:m 未注形状与位置尺寸公差 Geometrical tolerance for features without individual tolerance indications GB/T 1184-K eqv ISO 2768-2:K	批准 Approve		
	标准化 Standard		
	工艺 Technology		
	审核 Check		
	设计 Design	李志辉	2019.09.09
UNLESS OTHERWISE SPECIFIED	NAMES	SIGNATURE	DATE

MOONS' Slotless Brushless DC Motor

Shanghai Moons' Electric Co., Ltd.

This document is released for information only. Its reproduction in whole or in part or its dissemination to third parties is prohibited. All trademarks and registered trademarks appearing on this document are the property of their respective owners.

Type: ECH22060H24-S001 | Rev. A | SCALE 2:1 | SHEET 1 OF 1